

Data subject to change without prior notice
Edition 02/2026 © 2026 JMG Cranes S.p.A. All rights reserved
Rev. 02



Electric pick & carry cranes

MC50000RE

(imperial)

Maximum capacity
352300 lbs*ft

EU standards CE

UNI ISO 4301-1: A1
2006/42 CE-2014/30 UE-2014/35 UE
2000/14 CE and subsequent amendments.
UNI EN 12999:2025
and subsequent amendments.



JMG Cranes S.p.A.

Offices and plant: Via dell'Innovazione, 3 - 29010 Sarmato (PC) - Italy

Registered Office: Via Dante, 15 - 26100 Cremona - Italy

Administration: Via Bergamo, 142 - 26100 Cremona - Italy

+39 0523 8486

info@jmgcranes.com

www.jmgcranes.com





Features

- Radio-controlled battery-powered electric crane
- 7-section hydraulic sequential boom
- Front wheels drive with counter-rotation
- Hydraulic rotation of the boom on a slewing turret 360° continuous and unlimited
- 4 independent removable stabilizers, foldable for transport
- 2 removable counterweights

Optional

- Hydraulic winch
- 4-section hydraulic jib
- Men basket
- Customer paint colour

Load charts

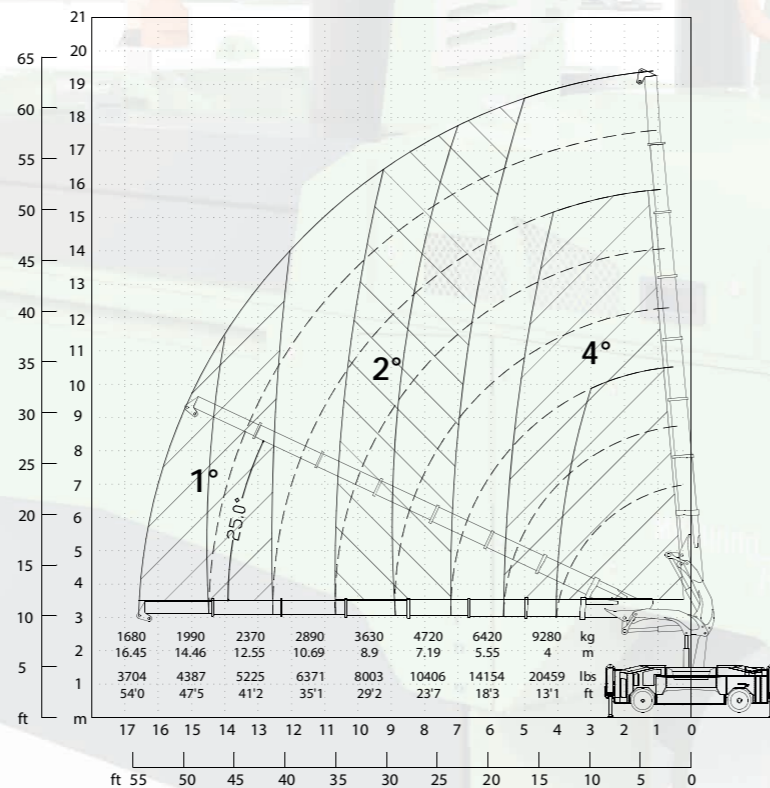
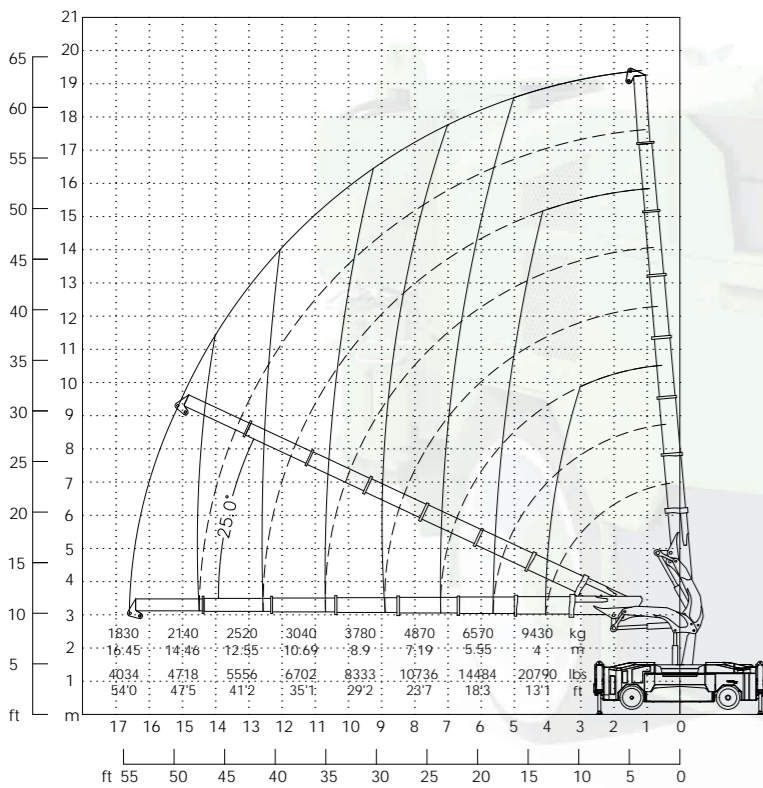

Hook

2 counterweights + stab.

N. MAX ROPE	20400 lbs
SINGLE ROPE	5600 lbs

Winch

2 counterweights + stab.



Technical features

Maximum capacity	352300 lbs*ft
Dimensions ft	16'-10" x 6'-9" x 9'-3"

- Front wheels drive nr.2 electric motors 10kW 96V AC
- Total lbs 47700 nr.2 removable counterweights lbs 4400 (lbs 2200+lbs 2200)
- Armoured plate battery 96V 1.240 Ah
- nr.2 front cushion 28x16x22" nr.2 rear cushion 28x10x22"
- Hydraulic rear steering -90°/+90° on rear axle
- L.M.I. Electronic system Moment limiter
- Automatic braking system
- Fabricated from preformed and welded quality steel plate
- Inclination angle +85°/-45° Rotation time 360°/70 s
- Electric motor 20kW 80V AC

Overall dimensions

