

JIMG[®]



MC100.08

metric

Portata Massima:
15.000 kg

MC100.08



Configurabile

Innovativa funzione di cambio ed innesto del braccio permette molteplici configurazioni.



Compatta

Ingombro dimensionale ridotto per effettuare manovre millimetriche in spazi stretti.



Versatile

Pensata per operare lavori diversi con configurazioni macchina diverse.



Normative Direttive



UNI ISO

4301-1:A1



UE / CE

2006/42 CE

2014/30 UE

2014/35 UE

2000/14

e successive mofifiche



OTHER

EN 13000:2014

ANSI/ASME B30.5-2011

e successive modifiche

Informazioni Tecniche

Portata massima

al gancio

15.000 kg

Peso macchina base

senza braccio

15.200 kg

Zavorre removibili

1.600 kg Z1
1.400 kg Z2

Trazione

Asse anteriore
2x 7.5Kw AC

Batteria

litio

autonomia fino 8 ore
80V 608Ah

Motore

35Kw AC
pompa cc variabile

Inclinazione

da -5° a 70° braccio

PLC

Indicatore di carico e limitatore
momento ribaltante

Freni

Sistema automatico
di frenatura elettrico-
meccanico +
stop on ramp

Braccio corto

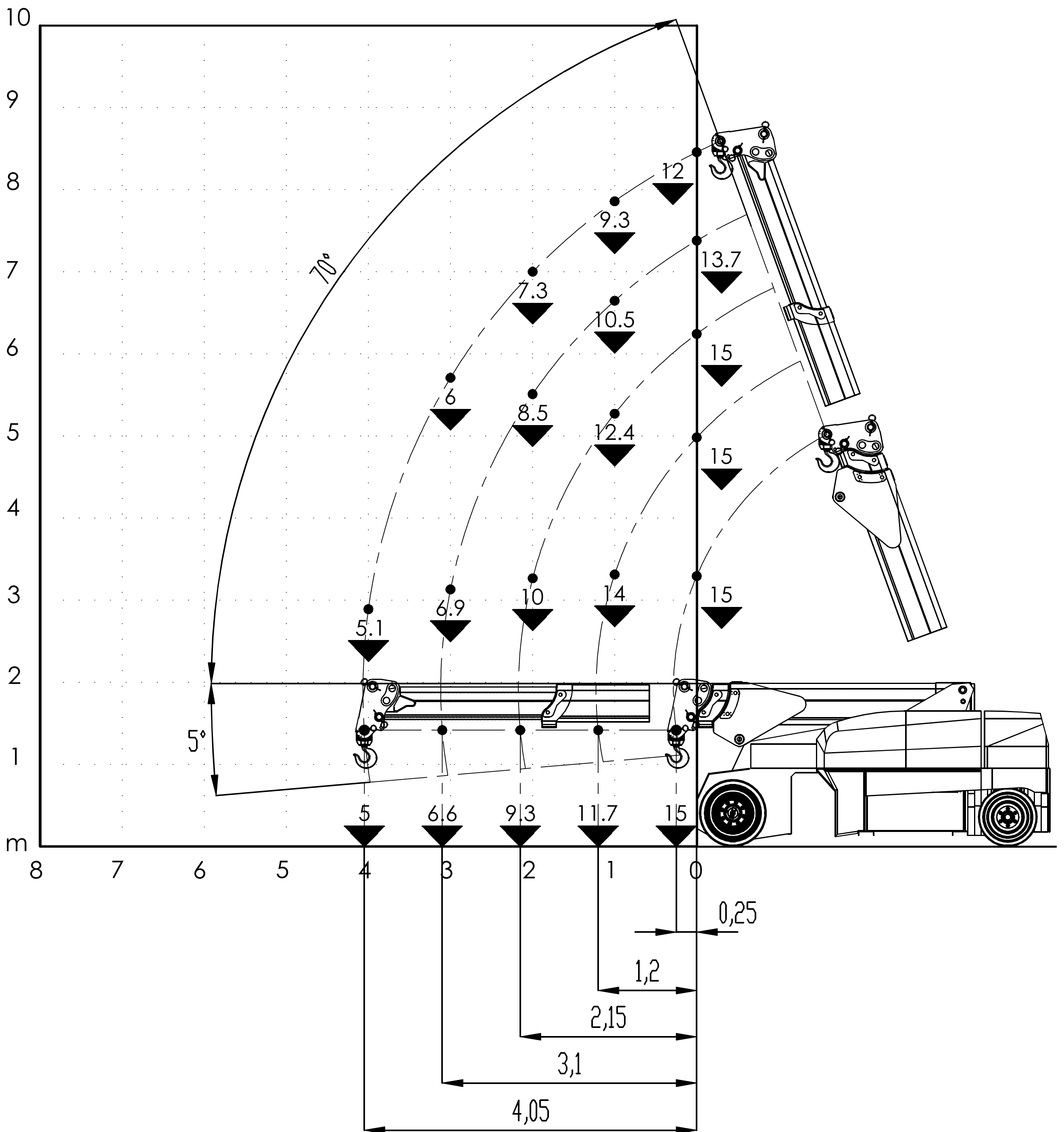

Gancio singolo

15.000 kg

Gancio doppio

15.000 kg

Argano

15.000 kg - 8°

+

Forca

10.000 kg - 0.8 m

Jib telescopico

6.000 kg - 2.4 m

Jib meccanico

7.500 kg - 0.75 m

Braccio lungo

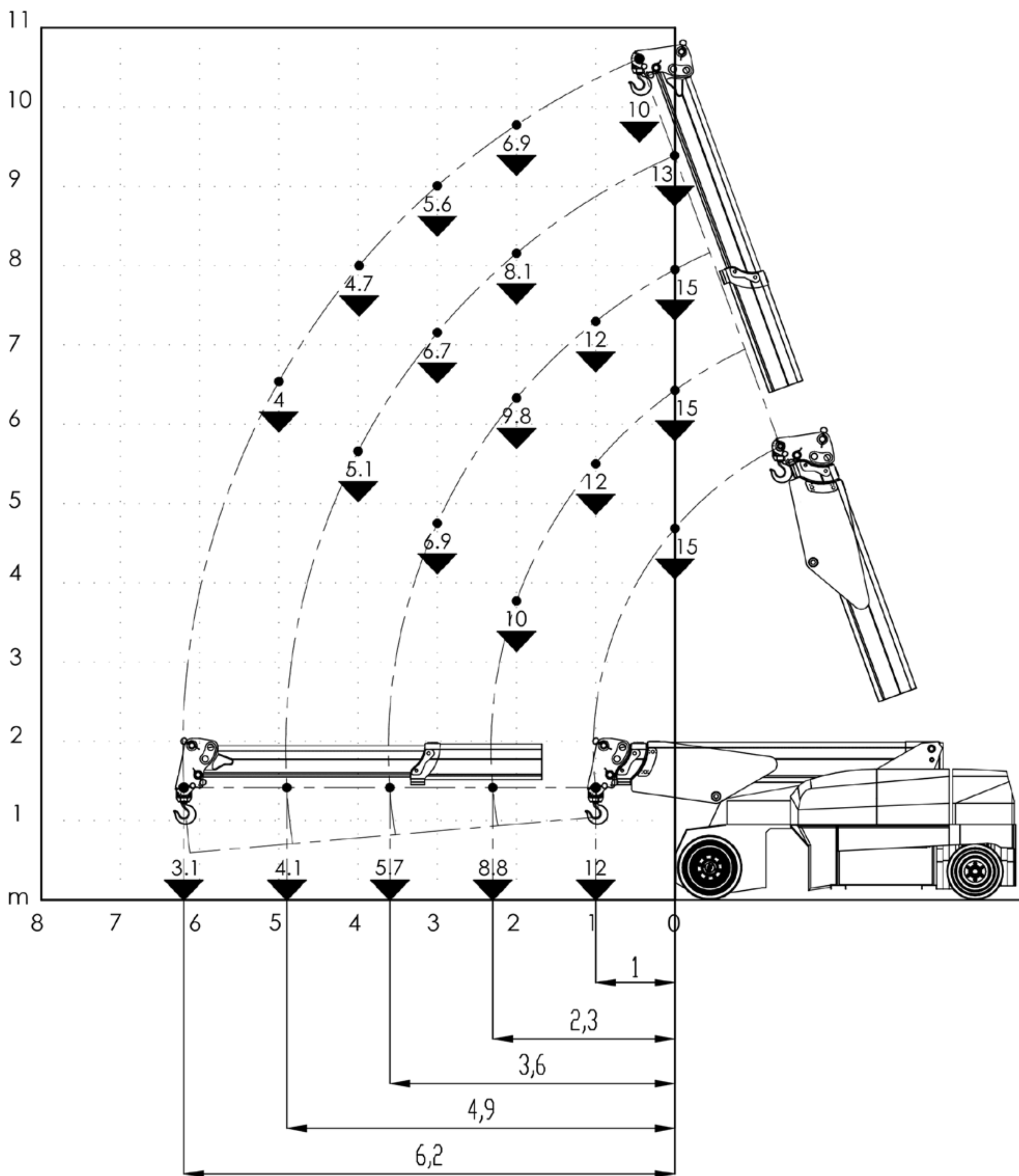

Gancio singolo

15.000 kg

Gancio doppio

15.000 kg

Argano

15.000 kg - 8°

+

Forca

8.000 kg - 0.8 m

Jib telescopico

6.000 kg - 2.4 m

Jib meccanico

7.500 kg - 0.75 m

Singolo sfilo

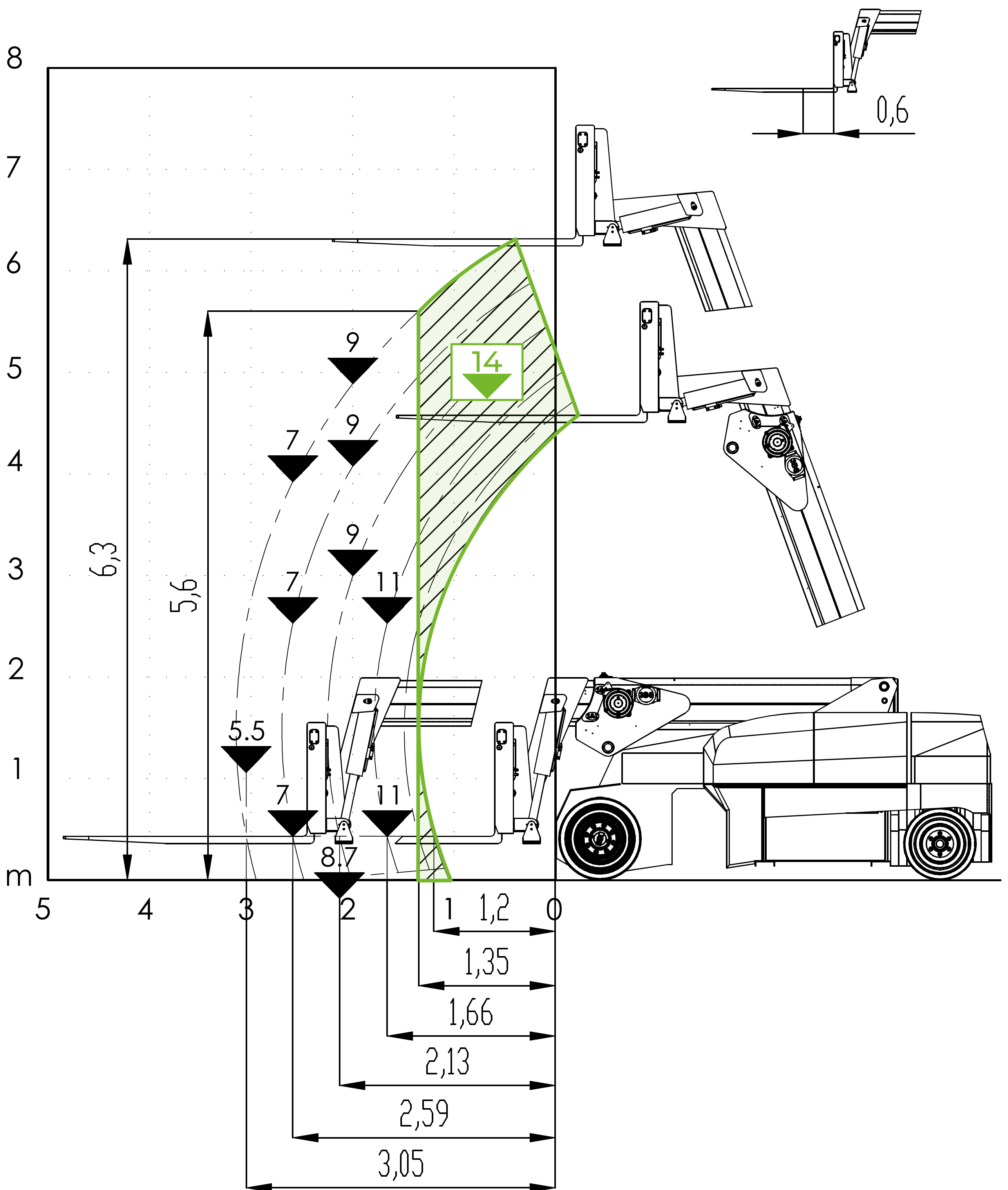

Gancio singolo

15.000 kg

Gancio doppio

15.000 kg

Forca

14.000 kg - 0.6 m



Il braccio a singolo sfilo permette di sfruttare tutta la portata delle forche da 14.000 kg nel range evidenziato nella tabella.

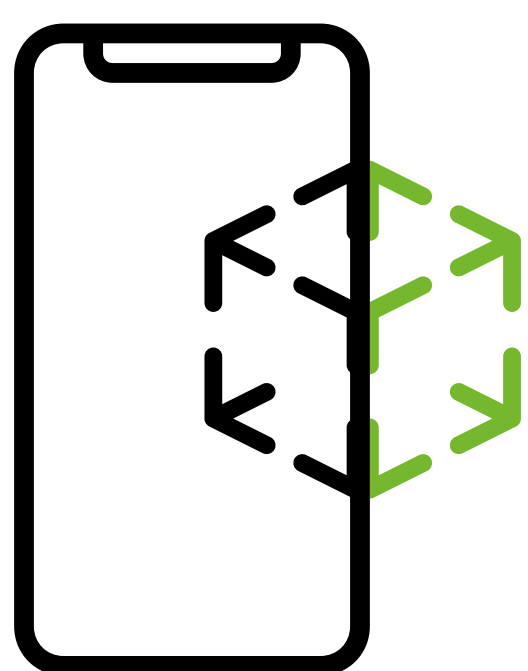
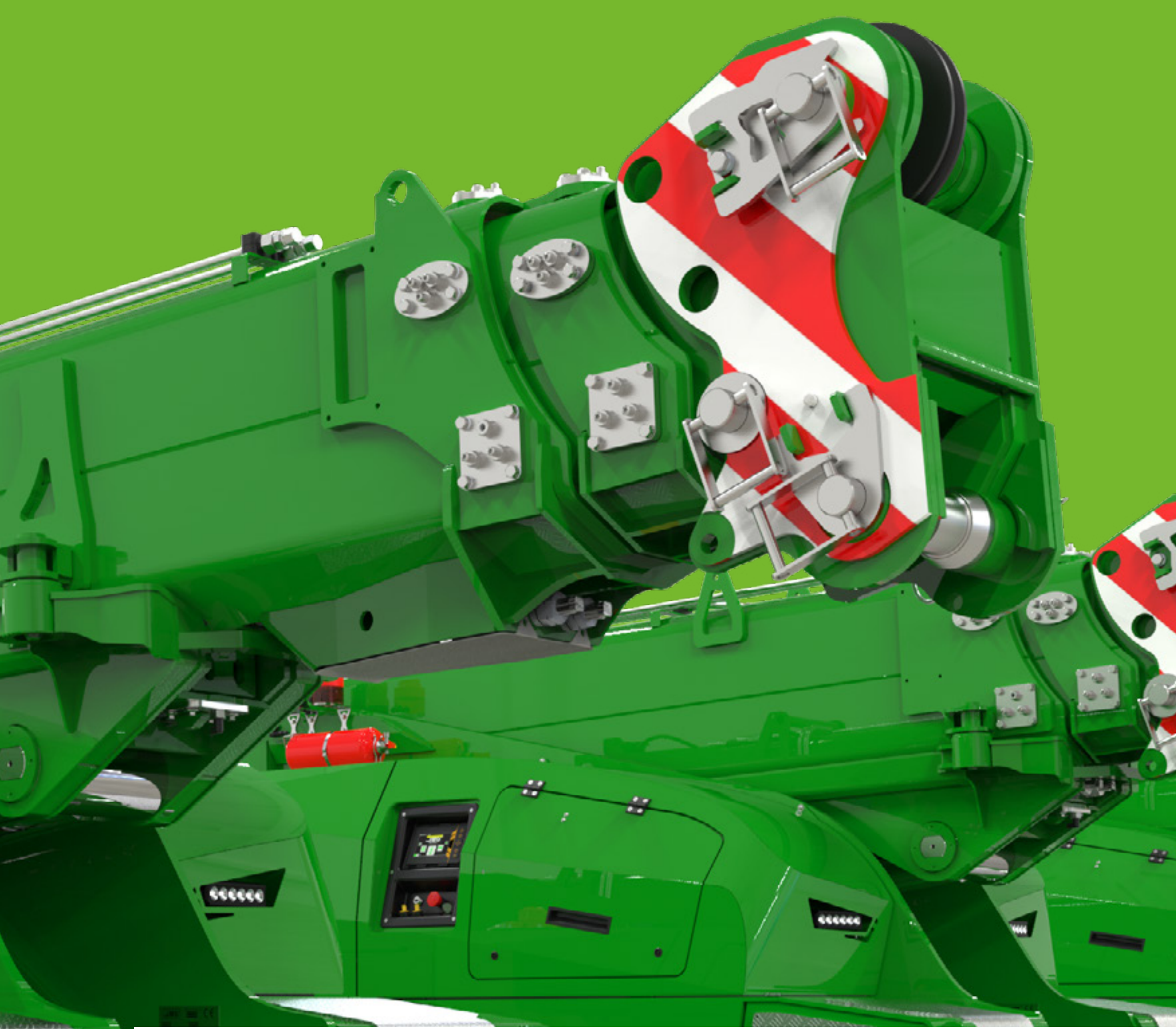

Realtà Aumentata

Visualizza gli ingombri, gli accessori e le caratteristiche principali direttamente nel luogo di utilizzo della gru.

Premendo il pulsante sottostante si potrà sfruttare la realtà aumentata per collocare la gru **JMG MC100.08** nello spazio sfruttando nativamente la fotocamera di iPhone.

AR disponibile solo su iPhone.

Optionals

01

Argano idraulico

02

Jib idraulico

03

Jib meccanico

04

Ruote antitraccia

05

Forca idraulica

06

Colore personalizzato



Dimensioni
Ingombro macchina base

MC100.08



3490mm - 1600mm - 2034mm

info@jmgcranes.com

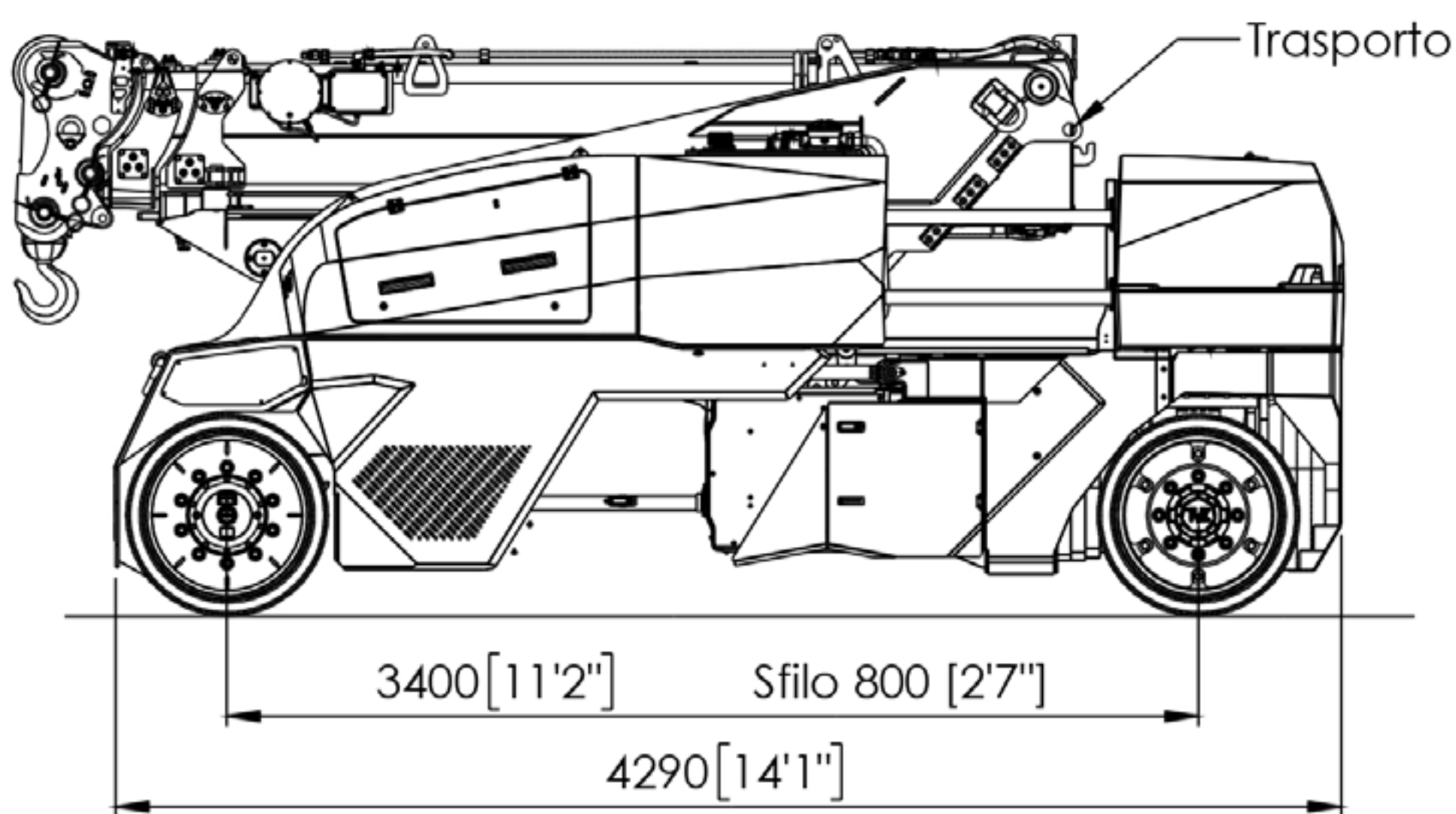
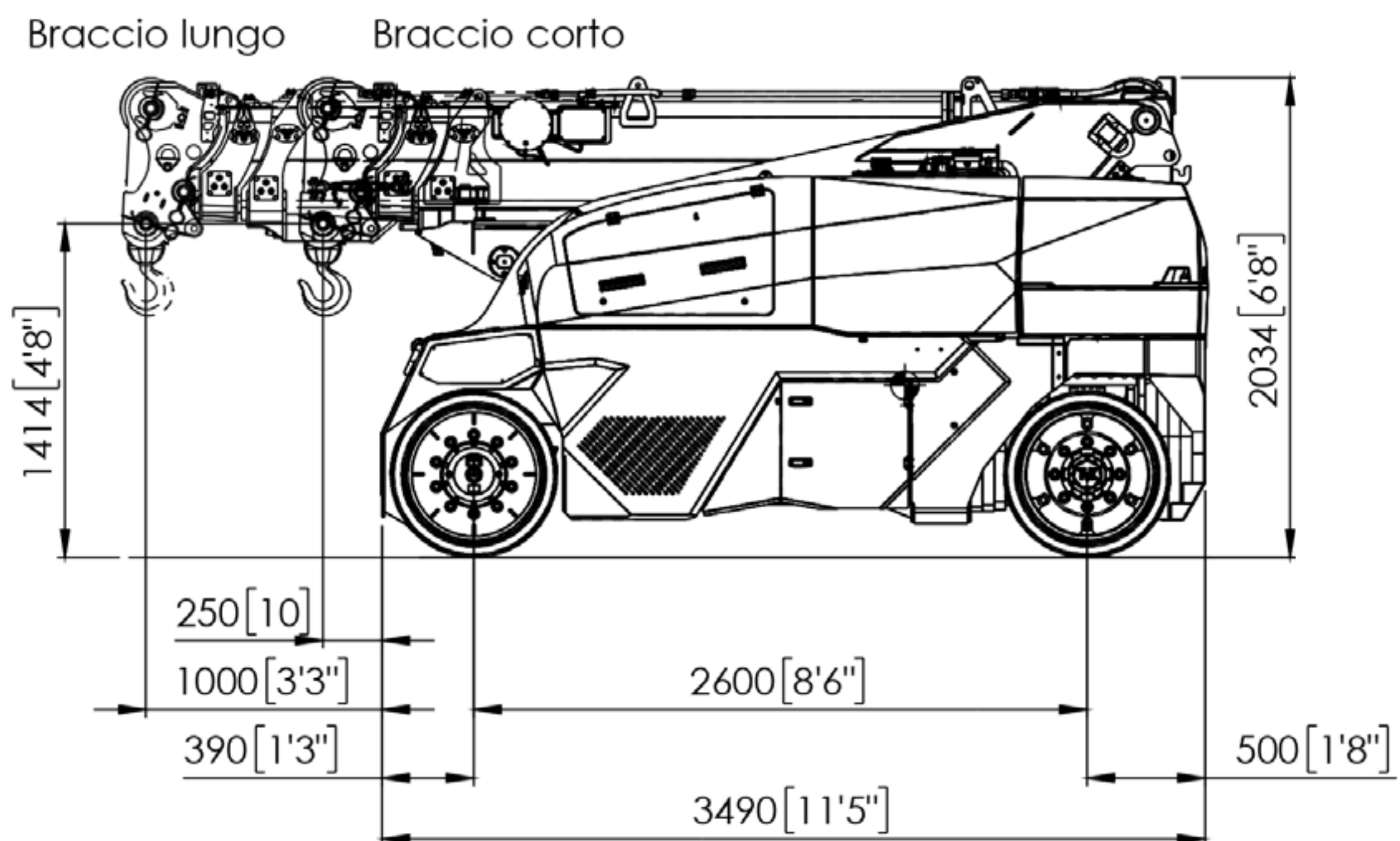
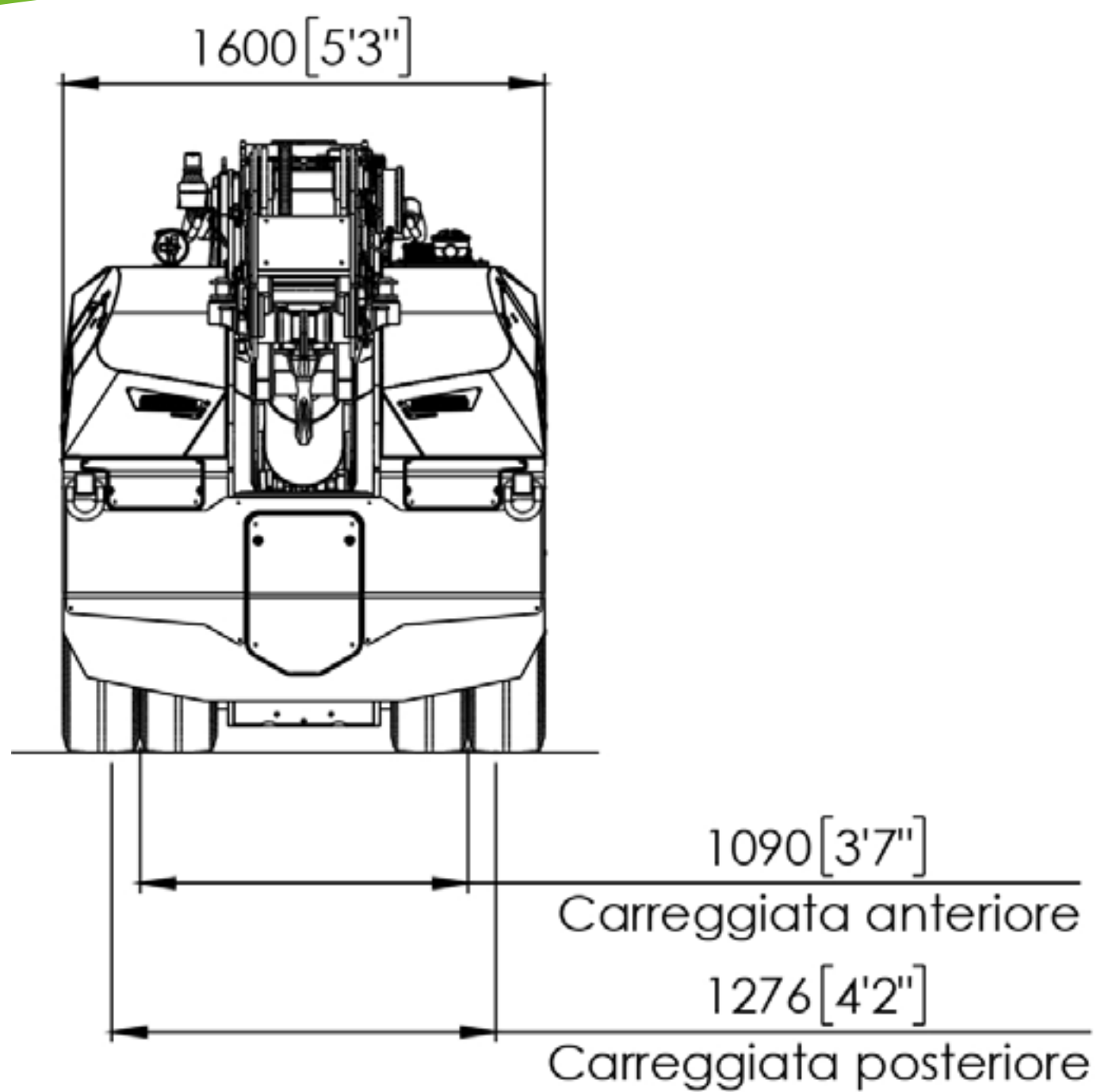

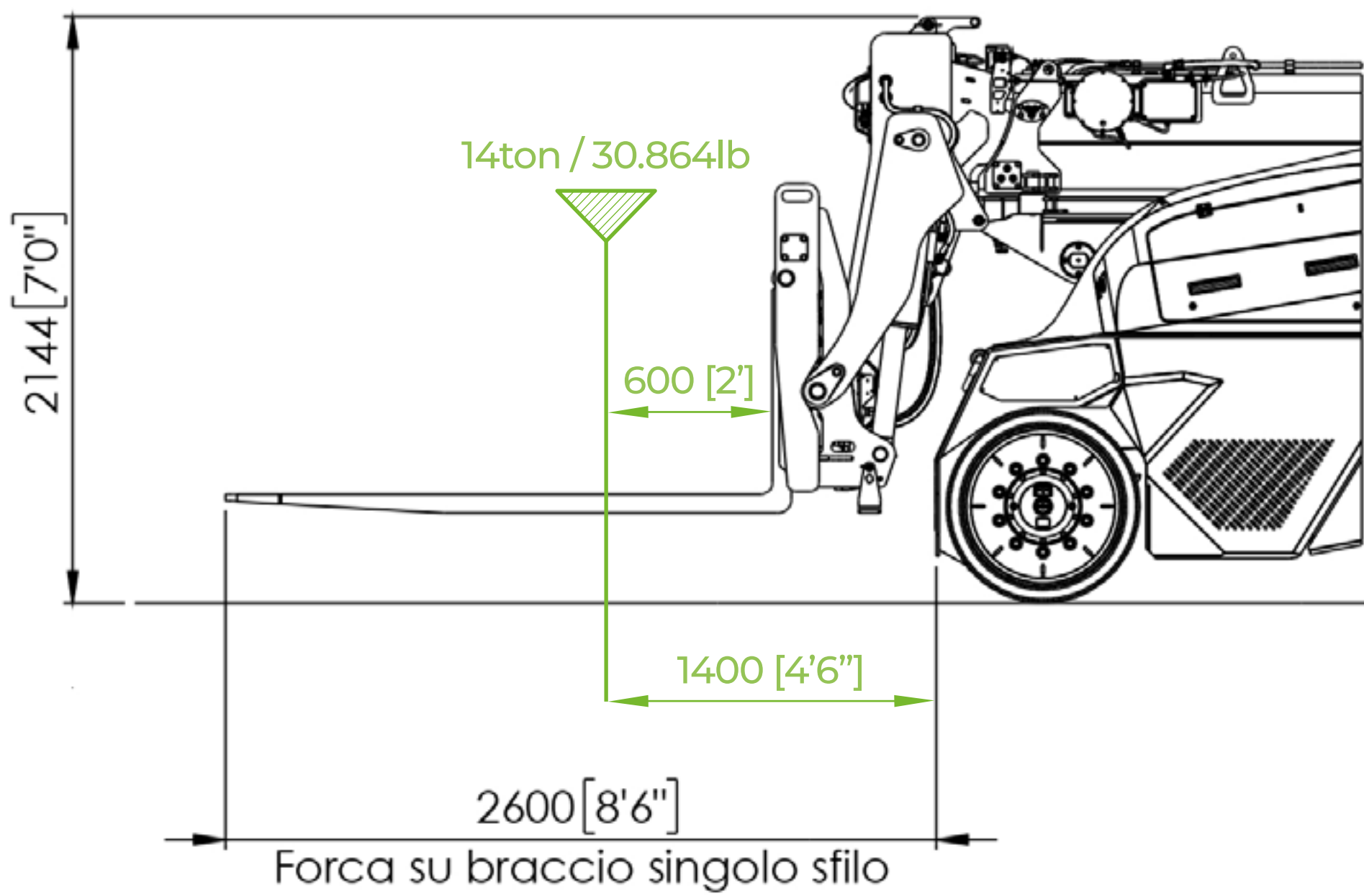
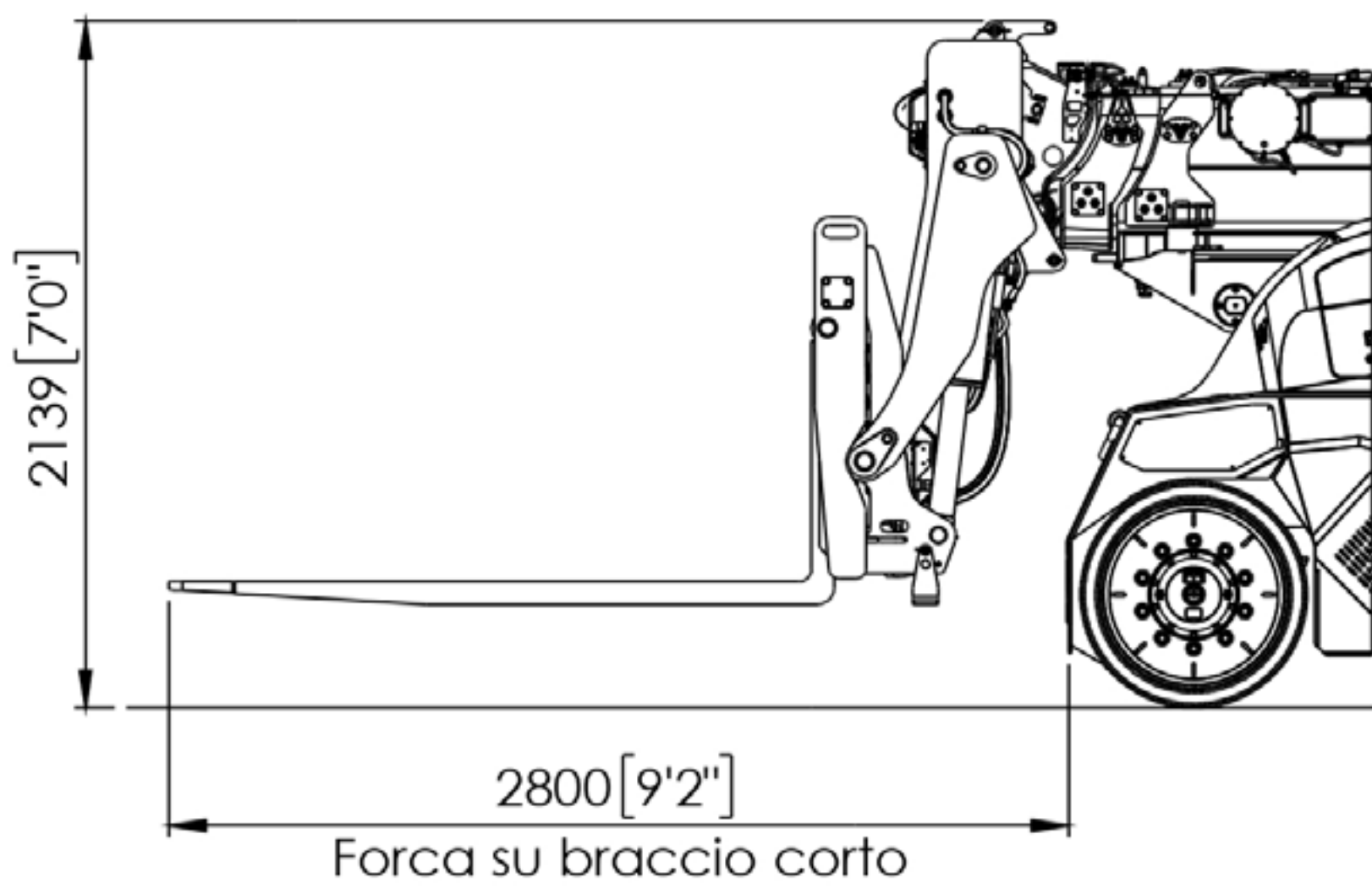
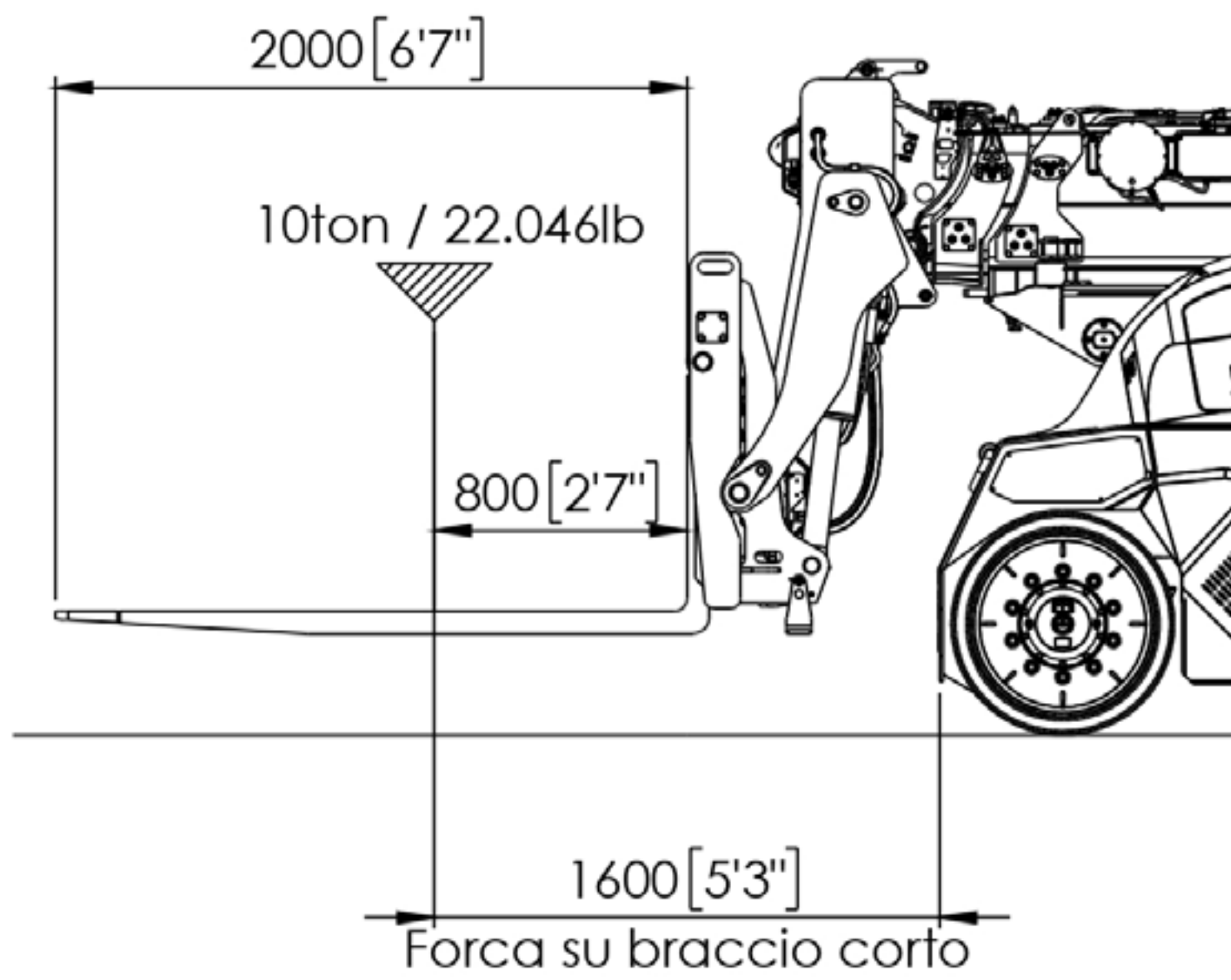

Ⓐ

Ⓑ

Ⓒ



Ⓑ

Braccio corto

Ⓐ

Braccio lungo

Ⓒ

Braccio singolo sfilo

JMG[®]

MC100.08





MC100.08 render





JMG Cranes S.p.A

Sede commerciale:

Via Bergamo 142
26100 CREMONA (CR)

Sede produttiva:

Via Zuccherificio 2
29010 SARMATO (PC)

+39 05238486

www.jmgcranes.com

info@jmgcranes.com